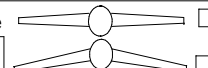

VOILERIE **CONCEPTION**  N° DESSIN
 E-MAIL **GRAND-VOILE** date
 Tel: **BATEAU** Longueur

type Gréement Tête 7/8 9/10 mat raide mat Souple droit cintré Nb barres de flèche 
 ralingue coulisseaux chariots bastingues guignol Enrouleur mat: Enrouleur bôme:

type de voile classique Lattes longue full batten multicoque croisière Voile au Tiers Jauge HN IRC ORC
 dériveur multicoque de sport Voile de planche voile de cape Voile Aurique Autre (ou règle de classe)

Usage Course croisière Grandre croisière Croisière côtière Club regate Regate Economique

Plan de coupe Cross-cut Verticale 1/2 Laize (option) Triradiale Biradiale Nb jonction horizontale 1 2 3

Surface <input type="text"/> m ²	Guindant coupe <input type="text"/> m	matériau 1	Largueur tissu <input type="text"/> m
Angle Bôme <input type="text"/> °	Chute coupe <input type="text"/> m	matériau 2	Recouvrement <input type="text"/> mm
Tête <input type="text"/> m	bordure coupe <input type="text"/> m	matériau 3	

Details: Nb lattes Nb latte forcée Nb Ris Nb BV Cuningham Ourlet mm Marques d'enroulements

Renforts: (type) Quadrangulaire Elliptique (composition) Multicoque Etoile Radial Radial + multicoque Pattes d'Oie (classique)

P	E	Remarque:	
PM	EM		
R	K	MGM	
L	HB	MGU	

SAIL LOFT **MAINSAIL**  N° design
 E-MAIL **DESIGN** date
 Phone: **Boat** LOA

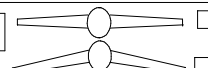
Rig Type mast head 7/8 9/10 Stiff mast soft mast straight bent Spreaders Nb: 
 Luff line Sliders Batten cars runners Diamond Running backstay Furling mast Furling Bome

SAIL type: classic "Long batten" full batten Cruising multihull Gaff sail Measurement Rules IRC ORC
 Dinghy Sport Multihull Surf sail Trial Sail Other: Other (class rule)

Use: offshore-racing Offshore cruising Coastal cruising Club race top race eco

Panel lay out Cross-cut Vertical 1/2 panel (option) Triradial Bi-radial Nb section seam 1 2 3

Sail area <input type="text"/> m ²	Luff (finished) <input type="text"/> m	Sailcloth 1	Cloth width <input type="text"/> m
Boom Angle <input type="text"/> °	Leech (finished) <input type="text"/> m	Sailcloth 2	Seam width <input type="text"/> mm
Head <input type="text"/> m	Foot (finished) <input type="text"/> m	Sailcloth 3	

Details: Batten Nb Full batten Nb Reef Nb Speed stripes Nb Cuningham Fold over mm furling marks

Patches (type) Quadrangular Elliptic (composition) Multilayer Spider Radial Radial + Layers Finger Patch (classic)

P	E	Remarks:	
PM	EM		
R	K	MGM	
L	HB	MGU	

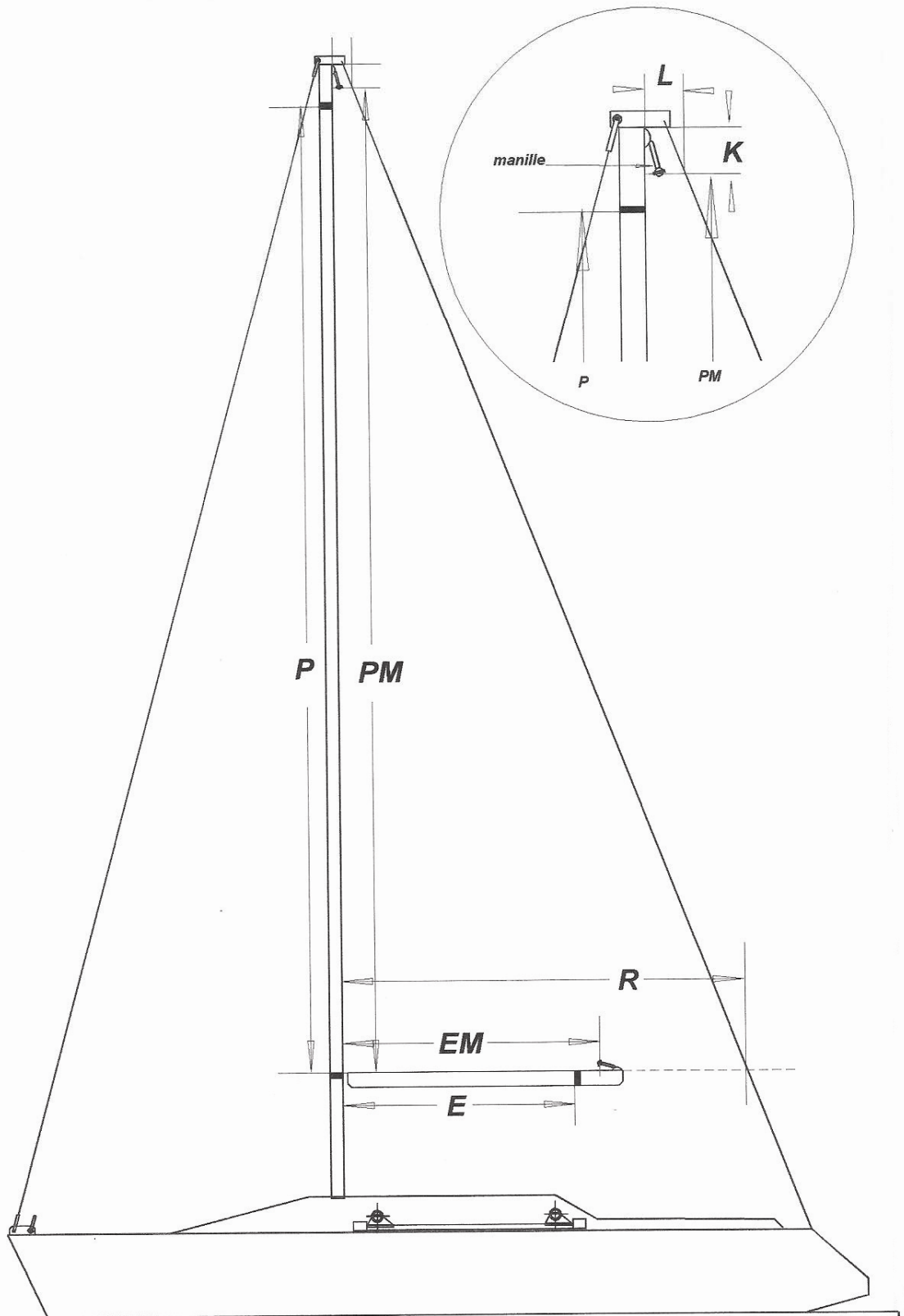

Prise de mesures pour grand-voile

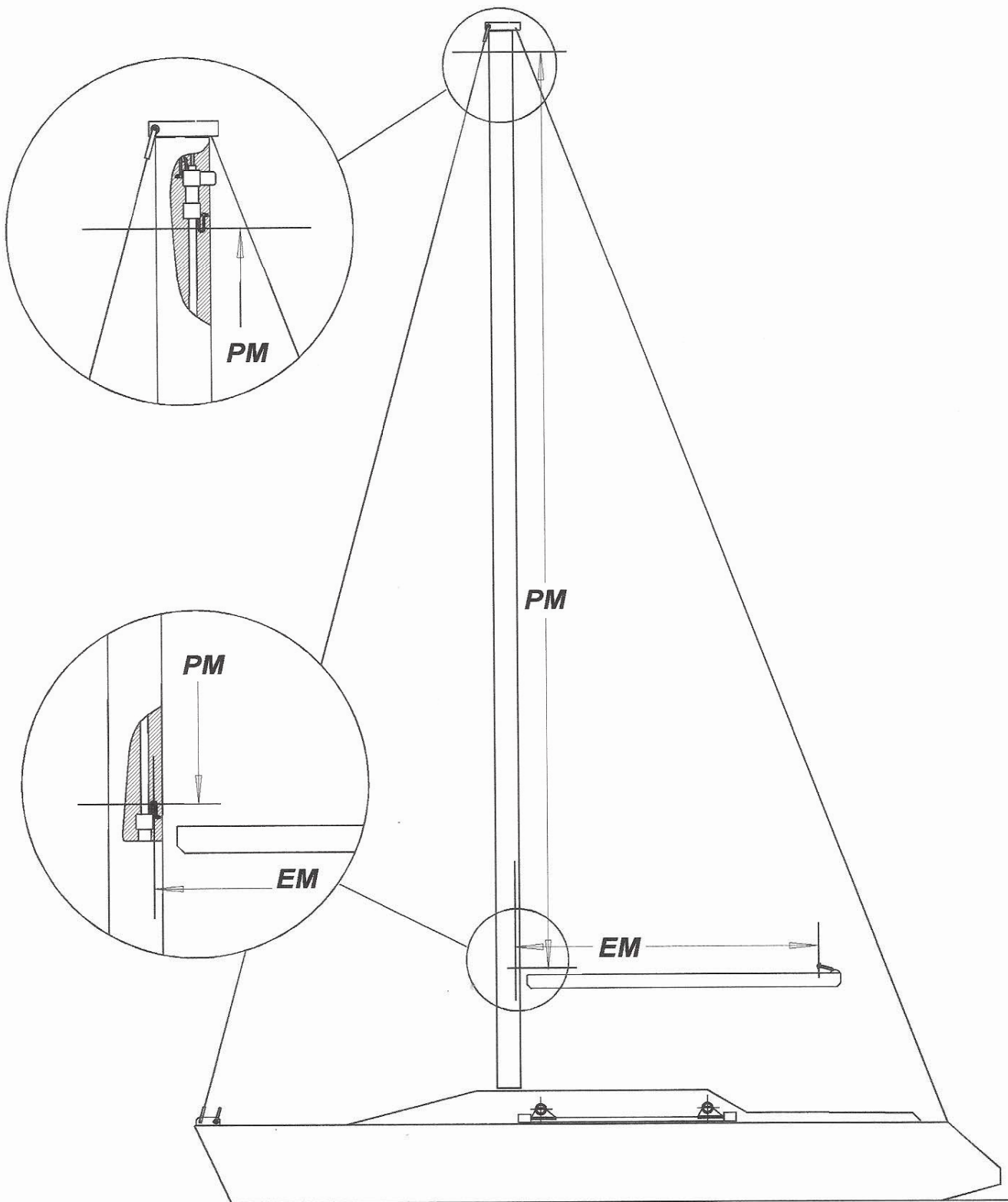

Prise de mesures pour grand-voile enrouleur